

BLOCK-MODIFIED WISHART MATRICES AND FREE POISSON LAWS

TEODOR BANICA AND ION NECHITA

ABSTRACT. We study the random matrices of type $\tilde{W} = (id \otimes \varphi)W$, where W is a complex Wishart matrix of parameters (dn, dm) , and $\varphi : M_n(\mathbb{C}) \rightarrow M_n(\mathbb{C})$ is a self-adjoint linear map. We prove that, under suitable assumptions, we have the $d \rightarrow \infty$ eigenvalue distribution formula $\delta m \tilde{W} \sim \pi_{mn\rho} \boxtimes \nu$, where ρ is the law of φ , viewed as a square matrix, π is the free Poisson law, ν is the law of $D = \varphi(1)$, and $\delta = tr(D)$.

INTRODUCTION

A complex Wishart matrix of parameters (dn, dm) is a random matrix of type $W = \frac{1}{dm}GG^*$, where G is a $dn \times dm$ matrix with independent complex $\mathcal{N}(0, 1)$ entries. In the limit $d \rightarrow \infty$, the eigenvalue distribution of W converges to a certain law π_t , with $t = m/n$, computed by Marchenko and Pastur in [16]. Later on, the free probability theory of Voiculescu [21], [22], [24] has led to a new, conceptual point of view on this result: the limiting law π_t is in fact the “free Poisson law” of parameter t .

These fundamental results have been subject to a number of extensions and generalizations. In particular, three types of “block-modified” versions of the Marchenko-Pastur theorem appeared in the recent random matrix and free probability literature:

- (1) The matrices of type $(1 \otimes E)W$, where E is the diagonal matrix formed by the n -roots of unity, were investigated some time ago in [3]. The limiting laws here are certain compound free Poisson laws, called free Bessel laws.
- (2) The matrices of type $(id \otimes tr(\cdot)1)W$, where tr is the normalized trace of the $n \times n$ matrices, appeared in connection with the quantum information theory problems investigated in [11]. The limiting laws here are the free Poisson laws.
- (3) The matrices of type $(id \otimes t)W$, where t is the transposition, were investigated by Aubrun in [2]. His computation, leading to shifted semicircles, was extended in [5], where the limiting law was shown to be a difference of free Poisson laws.

The main motivation for the above results comes from quantum information theory. In quantum information theory, the partial transposition map is known to be an “entanglement witness”: it allows to test if a quantum state (represented by a positive, unit trace matrix) is entangled, in the following sense. If a bipartite quantum state

2000 *Mathematics Subject Classification.* 60B20.

Key words and phrases. Wishart matrix, Poisson law.

$\rho \in M_d(\mathbb{C}) \otimes M_n(\mathbb{C})$ is separable (i.e. it can be written as a convex combination of product states $\rho_i^{(1)} \otimes \rho_i^{(2)}$), then its partial transposition $\rho^\Gamma = (id \otimes t)\rho$ is also a quantum state. However, if ρ is entangled, then ρ^Γ may fail to be positive. In the case where ρ^Γ is a positive matrix, the quantum state ρ is said to be PPT (Positive Partial Transpose). Hence, separable states are always PPT and non-PPT states are necessarily entangled. The equivalence of entanglement and non-PPT is known to hold only for total dimension smaller than 6 (2×2 or 2×3 product systems) and it fails for larger dimensions, in the sense that there exist PPT entangled states. In the same spirit as in [2], the results in [5] regarding the positivity of the support of the limit measure can be interpreted as results about typicality of PPT states for large quantum systems. The Wishart matrices (normalized to have unit trace) are known to be physically reasonable models for random quantum states on a tensor product $\mathbb{C}^d \otimes \mathbb{C}^n$, the parameter m of the Wishart distribution being related to the size of some environment \mathbb{C}^{dm} needed to define the state. So, as a conclusion, the various technical results in [2] and [5], not to be detailed here, indicate that when $m > 2$ and $n < m/4 + 1/m$, a typical state in $\mathbb{C}^d \otimes \mathbb{C}^n$ is PPT.

The starting point of the present work was the following observation: the matrices W , $(1 \otimes E)W$, $(id \otimes tr(\cdot)1)W$ and $(id \otimes t)W$ appearing in the above considerations are all particular cases of matrices of the form $\tilde{W} = (id \otimes \varphi)W$, where $\varphi : M_n(\mathbb{C}) \rightarrow M_n(\mathbb{C})$ is a linear map. So, a natural problem is to try to compute the asymptotic eigenvalue distribution, with $d \rightarrow \infty$, of such general “block-modified” Wishart matrices \tilde{W} .

In this paper we solve this problem, under suitable assumptions on φ . Let us first recall that the linear maps of type $\varphi : M_n(\mathbb{C}) \rightarrow M_n(\mathbb{C})$ are in correspondence with the matrices $\Lambda \in M_n(\mathbb{C}) \otimes M_n(\mathbb{C})$. We will use the following formula for this correspondence:

$$\varphi(A) = (Tr \otimes id)[(t \otimes id)\Lambda \cdot (A \otimes 1)]$$

Here Tr and t denote the usual trace and transposition of the $n \times n$ matrices. This correspondence, when restricted to the subclasses of completely positive maps, is known in quantum information theory as the Choi-Jamiolkowski isomorphism. See [7].

Given a real positive measure μ , not necessarily of mass 1, we denote by π_μ the corresponding compound free Poisson law. Also, we write $\tilde{W} \sim \mu$ if the $d \rightarrow \infty$ asymptotic eigenvalue distribution of \tilde{W} is μ . With these notations, our main result is as follows:

Theorem. *Let $\tilde{W} = (id \otimes \varphi)W$, where W is a complex Wishart matrix of parameters (dn, dm) , and where $\varphi : M_n(\mathbb{C}) \rightarrow M_n(\mathbb{C})$ is a self-adjoint linear map, coming from a matrix $\Lambda \in M_n(\mathbb{C}) \otimes M_n(\mathbb{C})$. Then, under suitable “planar” assumptions on φ , we have $\delta m \tilde{W} \sim \pi_{mnp} \boxtimes \nu$, with $\rho = law(\Lambda)$, $\nu = law(D)$, $\delta = tr(D)$, where $D = \varphi(1)$.*

This result generalizes the above-mentioned computations in [2], [5], [11], [16]. The proof is quite standard, first by applying the Wick formula, then by letting $d \rightarrow \infty$ and by using Biane’s bijection in [8], and finally by using Speicher’s free cumulants [19].

We should mention that the combinatorics of some very general “modified Wishart” matrices was already investigated some time ago by Graczyk, Letac and Massam [12].

Our assumption that the modification is performed blockwise is of course a key one: this makes the whole combinatorics controllable, and leads to the above result.

Let us also mention that, as kindly pointed out to us by the referee, there should be as well a direct proof for the above result. Indeed, let e_{ij} be the matrix units of the inclusion $M_n(\mathbb{C}) \subset M_{nd}(\mathbb{C})$. It is known from Voiculescu's work [23] that e_{ij} is asymptotically free from W . Now the matrix \tilde{W} can be viewed as a linear combination of matrices of type $e_{ij}W e_{kl}$, so, in principle, combinatorial computations of free probabilistic flavour, in the lines of the book by Nica-Speicher [17] for example, should probably do as well the job. Several proofs of this type, for related results, have been worked out, e.g. in [1], [9], [15], [18].

We assume in the above statement that φ is self-adjoint, in the sense that it maps self-adjoints to self-adjoints. It would be interesting to understand as well the non-self-adjoint case, as to cover the "free Bessel" computation in [3], where $\varphi(A) = EA$, with E being the diagonal matrix formed by the n -roots of unity. We should mention that our formula $\delta m\tilde{W} \sim \pi_{mnp} \boxtimes \nu$ covers as well this situation, but only in the formal sense of [3].

Some other problems concern a possible relation with the complex reflection groups. Indeed, the exact planarity assumptions needed on φ , not to be detailed here, concern certain sets of partitions $P_{\text{even}}(2k, 2k)$, for which we refer to Definition 4.4 below, and these sets are known to span the centralizer spaces for the hyperoctahedral group [4].

The above questions are probably all related. A common answer to them should probably come from a very general random matrix/free probability formula, extending our present formula $\delta m\tilde{W} \sim \pi_{mnp} \boxtimes \nu$. But we have no further results here.

The paper is organized as follows: in 1-2 we perform a joint study of the compound free Poisson laws and of the block-modified Wishart matrices, and in 3-4 we develop a number of supplementary ingredients, and we state and prove our main result.

Acknowledgements. We would like to thank Mireille Capitaine, Benoît Collins, Maxime Février and Camille Male for several useful discussions, and the anonymous referee of this paper for a number of useful comments and suggestions. The work of T.B. was supported by the ANR grant "Granma". I.N. acknowledges financial support from the ANR project OSvsQPI 2011 BS01 008 01 and from a CNRS PEPS grant.

1. POISSON LAWS

Our starting point is the Marchenko-Pastur theorem [16]. Let us recall that a complex Wishart matrix of parameters (N, M) is a random $N \times N$ matrix of type $W = \frac{1}{M}GG^*$, where G is a $N \times M$ matrix with independent complex Gaussian $\mathcal{N}(0, 1)$ entries.

Theorem 1.1. *In the limit $N, M \rightarrow \infty$, $M/N \rightarrow t \geq 0$, the law of tW converges to*

$$\pi_t = \max(1-t, 0)\delta_0 + \frac{\sqrt{4t - (x-1-t)^2}}{2\pi x} 1_{[(\sqrt{t}-1)^2, (\sqrt{t}+1)^2]}(x) dx$$

which is called Marchenko-Pastur law of parameter $t \geq 0$.

Proof. This follows for instance by checking, by using the Wick formula, that the asymptotic moments of W coincide with those of π_t . We refer here the reader to section 2 below, where we present a generalization of this theorem, along with a complete proof. \square

In order to deal with the block-modified case, we will need a free probability point of view on π_t . The idea is that π_t appears naturally via a “free Poisson limit” procedure.

We recall from [24] that a noncommutative probability space is a pair (A, φ) , where A is a unital C^* -algebra, and $\varphi : A \rightarrow \mathbb{C}$ is a positive unital trace. The law of a self-adjoint element $a \in A$ is the probability measure on the spectrum of a (which is a compact subset of \mathbb{R}) given by $\int f(x)d\mu(x) = \varphi(f(a))$, for any continuous function $f : \mathbb{R} \rightarrow \mathbb{C}$.

We will heavily use the notion of freeness, and the free convolution operation for real probability measures \boxplus , introduced by Voiculescu in [21]. We refer to the book [24], in its entirety, for full details regarding the notion of freeness, and the operation \boxplus .

In free probability here are two conceptual results about π_t , as follows:

Proposition 1.2. *We have $\pi_{s+t} = \pi_s \boxplus \pi_t$, for any $s, t \geq 0$, so that the Marchenko-Pastur laws form a semigroup with respect to Voiculescu’s free convolution operation.*

Proof. We recall from [21] that the operation \boxplus for real probability measures is linearized by the R -transform, constructed as follows: first, we let $f(y) = 1 + m_1y + m_2y^2 + \dots$ be the moment generating function of our measure, so that $G(\xi) = \xi^{-1}f(\xi^{-1})$ is the Cauchy transform; then we set $R(y) = K(y) - y^{-1}$, where $K(y)$ is such that $G(K(y)) = y$.

By Stieltjes inversion, the Cauchy transform of π_t is given by:

$$G(\xi) = \frac{(\xi + 1 - t) + \sqrt{(\xi + 1 - t)^2 - 4\xi}}{2\xi}$$

Thus we can compute the R -transform, by proceeding as follows:

$$\begin{aligned} \xi G^2 + 1 = (\xi + 1 - t)G &\implies Ky^2 + 1 = (K + 1 - t)y \\ &\implies Ry^2 + y + 1 = (R + 1 - t)y + 1 \\ &\implies R = t/(1 - y) \end{aligned}$$

Now since the expression $t/(1 - y)$ is linear in t , this gives the result. \square

Theorem 1.3. *We have the free Poisson limit formula*

$$\pi_t = \lim_{n \rightarrow \infty} \left(\left(1 - \frac{t}{n} \right) \delta_0 + \frac{t}{n} \delta_1 \right)^{\boxplus n}$$

so that π_t is called as well “free Poisson law” of parameter $t \geq 0$.

Proof. This result is once again well-known, see e.g. Speicher [20] or Hiai and Petz [13], and is for instance a particular case of Theorem 1.5 below. \square

In what follows we will need some generalizations of the above results. The class of “compound free Poisson laws” was introduced by Speicher in [20], studied by Hiai and

Petz in [13], then further studied in [3], [6]. Since we will be only interested in the “discrete case”, it is technically convenient to introduce these distributions as follows.

Definition 1.4. For $\mu = \sum_{i=1}^s c_i \delta_{z_i}$ with $c_i > 0$ and $z_i \in \mathbb{R}$, we let

$$\pi_\mu = \text{law} \left(\sum_{i=1}^s z_i \alpha_i \right)$$

where the variables α_i are self-adjoint free Poisson of parameter c_i , free.

Observe that we don't necessarily assume μ to be of mass 1. Observe also that we don't assume the numbers z_i to be distinct: the fact that we can indeed do so comes from Proposition 1.2, which shows that the distribution π_μ is indeed well-defined.

Theorem 1.5. We have the Poisson limit formula

$$\pi_\mu = \lim_{n \rightarrow \infty} \left(\left(1 - \frac{c}{n}\right) \delta_0 + \frac{1}{n} \mu \right)^{\boxplus n}$$

where $c = \text{mass}(\mu)$, so that π_μ is called “compound free Poisson law” associated to μ .

Proof. This result is from [6], we present below the idea of the proof. Let ρ_n be the measure appearing in the statement, under the convolution sign. We have:

$$G_{\rho_n}(\xi) = \left(1 - \frac{c}{n}\right) \frac{1}{\xi} + \frac{1}{n} \sum_{i=1}^s \frac{c_i}{\xi - z_i}$$

Now since $K_{\rho_n}(y) = y^{-1} + R_{\rho_n}(y) = y^{-1} + R/n$, where $R = R_{\rho_n^{\boxplus n}}(y)$, we get:

$$y = \left(1 - \frac{c}{n}\right) \frac{1}{y^{-1} + R/n} + \frac{1}{n} \sum_{i=1}^s \frac{c_i}{y^{-1} + R/n - z_i}$$

Now multiplying by n/y , rearranging the terms, and letting $n \rightarrow \infty$, we get:

$$\frac{c + yR}{1 + yR/n} = \sum_{i=1}^s \frac{c_i}{1 + yR/n - yz_i} \implies R_{\pi_\mu}(y) = \sum_{i=1}^s \frac{c_i z_i}{1 - yz_i}$$

On the other hand, let α be the sum of free Poisson variables in the statement. By using the R -transform formula in the proof of Proposition 1.2, we have:

$$R_{\alpha_i}(y) = \frac{c_i}{1 - y} \implies R_{z_i \alpha_i}(y) = \frac{c_i z_i}{1 - yz_i} \implies R_\alpha(y) = \sum_{i=1}^s \frac{c_i z_i}{1 - yz_i}$$

Thus we have indeed the same formula as above, and we are done. \square

Finally, we will need the notion of free cumulant, introduced by Speicher in [19]. The free cumulants $\kappa_p(a)$ of a self-adjoint variable a are the coefficients of its R -transform:

$$R_a(y) = \sum_{p=0}^{\infty} \kappa_{p+1}(a) y^p$$

With $\kappa_\pi(a) = \prod_{b \in \pi} \kappa_{\#b}(a)$, where the product is over all blocks of π , and $\#$ is the size of blocks, we have then the following moment-cumulant formula, due to Speicher [19]:

$$\varphi(a^p) = \sum_{\pi \in NC(p)} \kappa_\pi(a)$$

For concrete applications, it is rather the converse statement that we will use: whenever we have a sequence of numbers $\kappa_p(a)$ such the above moment formula holds for any $k \in \mathbb{N}$, it follows that these numbers $\kappa_p(a)$ are the free cumulants of a , see [19].

The following will be our main tool for detecting compound free Poisson laws.

Theorem 1.6. *The free cumulants of π_μ are the moments of μ .*

Proof. We write $\mu = \sum_{i=1}^s c_i \delta_{z_i}$ with $c_i > 0$ and $z_i \in \mathbb{R}$. We know from the proof of Theorem 1.5 that the R -transform of π_μ is:

$$R(y) = \sum_{i=1}^s \frac{c_i z_i}{1 - y z_i} = \sum_{i=1}^s \sum_{p=0}^{\infty} c_i z_i^{p+1} y^p = \sum_{p=0}^{\infty} \left(\sum_{i=1}^s c_i z_i^{p+1} \right) y^p$$

Now since the free cumulants are the coefficients of R , this gives the result. \square

2. WISHART MATRICES

Consider the embedding $NC(p) \subset S_p$ obtained by “cycling inside each block”. That is, each block $b = \{b_1, \dots, b_k\}$ with $b_1 < \dots < b_k$ of a given noncrossing partition $\pi \in NC(p)$ produces by definition the cycle $(b_1 \dots b_k)$ of the corresponding permutation $\pi \in S_p$.

Observe that the number of blocks of $\pi \in NC(p)$ corresponds in this way to the number of cycles of the corresponding permutation $\pi \in S_p$. This number will be denoted $|\pi|$.

For $\pi \in NC(p)$ we denote by $||\pi||$ the number of blocks of π having even size. We will need a number of facts on partitions, summarized in the following statement:

Lemma 2.1. *If $\gamma \in NC(p)$ is the one-block partition, then $|\pi| + |\pi\gamma^{-1}| \leq p + 1$, with equality iff $\pi \in NC(p)$. In addition, for $\pi \in NC(p)$ we have:*

- (1) $|\gamma^{-1}\pi| = |\pi\gamma^{-1}| = p + 1 - |\pi|$.
- (2) $|1| + |\pi^l\gamma| = |\pi\gamma^{-1}| + |\pi^{l+1}|$, for any $l \in \mathbb{Z}$.
- (3) $|\gamma\pi| = |\pi\gamma| = ||\pi|| + 1$.

Proof. Observe first that $\gamma \in S_p$ is the full cycle, $\gamma = (1 \dots p)$. Let also $1 \in NC(p)$ be the p -block partition, so that the associated permutation $1 \in S_p$ is the identity.

It is known that $l(\pi) = p - |\pi|$ is the length of permutations, so that $d(\pi, \sigma) = l(\pi\sigma^{-1})$ is the usual distance on S_p . Now the triangle inequality $d(1, \gamma) \leq d(1, \pi) + d(\pi, \gamma)$ reads $p - 1 \leq (p - |\pi|) + (p - |\pi\gamma^{-1}|)$, so we have $|\pi| + |\pi\gamma^{-1}| \leq p + 1$, as claimed. For the assertion regarding the case where we have equality, see Biane [8].

(1) This is clear from the first assertion, or from the well-known fact that $\gamma^{-1}\pi, \pi\gamma^{-1}$ have the same cycle structure as the right and left Kreweras complements of π .

(2) By using $|1| = p$ and $|\pi\gamma^{-1}| = p + 1 - |\pi|$, we must prove the following formula:

$$|\pi^l\gamma| - 1 = |\pi^{l+1}| - |\pi|$$

Observe first that this formula holds for $\pi = \gamma$. We will prove this formula by recurrence on the number of blocks of π . Since π is noncrossing, it is enough to check the stability of the above formula by “concatenation”, $\pi = (\pi_1, \pi_2)$. Since the right term of the above formula is additive with respect to concatenation, we have to prove that the left term is additive as well with respect to concatenation, i.e. we have to prove that:

$$|(\pi_1, \pi_2)^l\gamma| - 1 = (|\pi_1^l\gamma_1| - 1) + (|\pi_2^l\gamma_2| - 1)$$

With $\sigma_1 = \pi_1^l$ and $\sigma_2 = \pi_2^l$, the formula to be proved becomes:

$$|(\sigma_1, \sigma_2)\gamma| - 1 = (|\sigma_1\gamma_1| - 1) + (|\sigma_2\gamma_2| - 1)$$

In order to prove this latter formula, we use the following key identity:

$$(\gamma_1, \gamma_2) = \gamma(k, p)$$

More precisely, by using this identity, we have as claimed:

$$|\sigma_1\gamma_1| + |\sigma_2\gamma_2| = |(\sigma_1, \sigma_2)(\gamma_1, \gamma_2)| = |(\sigma_1, \sigma_2)\gamma(k, p)| = |(\sigma_1, \sigma_2)\gamma| + 1$$

Here at right we have used the general fact that $|\pi(a, b)| = |\pi| + 1$ when a, b are in the same cycle of π , and $|\pi(a, b)| = |\pi| - 1$ if a, b are in different cycles of π , and the fact that, in the above situation, k, p must be in the same cycle of $(\sigma_1, \sigma_2)\gamma$.

(3) This is the combinatorial lemma from our previous paper [5], which follows as well from (2). Indeed, at $l = 1$ the formula in (2) becomes $|1| + |\pi\gamma| = |\pi\gamma^{-1}| + |\pi^2|$, so:

$$\begin{aligned} |\pi\gamma| &= |\pi\gamma^{-1}| + |\pi^2| - |1| \\ &= (p + 1 - |\pi|) + (|\pi| + ||\pi||) - p \\ &= ||\pi|| + 1 \end{aligned}$$

Together with the fact that $|\pi\gamma| = |\gamma\pi|$, this gives the result. \square

Consider now a complex Wishart matrix of parameters (dn, dm) , $W = \frac{1}{dm}GG^*$, where G is a $dn \times dm$ matrix with independent complex $\mathcal{N}(0, 1)$ entries. As explained in the introduction, we are interested in the study of the “block-modified” versions of W , which are defined as follows:

Definition 2.2. *Associated to any Wishart matrix W of parameters (dn, dm) and any linear map $\varphi : M_n(\mathbb{C}) \rightarrow M_n(\mathbb{C})$ is the “block-modified” matrix $\tilde{W} = (id \otimes \varphi)W$.*

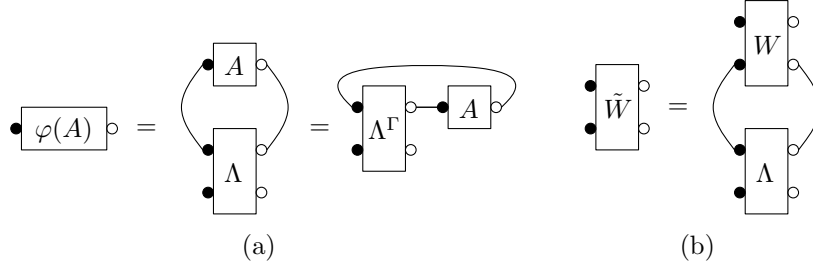

FIGURE 1. (a) The action of the map φ through Λ , and (b) the block-modified Wishart matrix \tilde{W} as the action of Λ on W .

In what follows, the idea will be to relate the limiting $d \rightarrow \infty$ eigenvalue distribution of \tilde{W} to the usual eigenvalue distribution of φ , viewed as a square matrix.

In order to view φ as a square matrix, we use the following correspondence:

Definition 2.3. *Associated to any linear map $\varphi : M_n(\mathbb{C}) \rightarrow M_n(\mathbb{C})$ is the square matrix $\Lambda \in M_n(\mathbb{C}) \otimes M_n(\mathbb{C})$ given by*

$$\varphi(A) = (Tr \otimes id)[(t \otimes id)\Lambda \cdot (A \otimes 1)]$$

where Tr and t are the usual trace and transposition of the $n \times n$ matrices.

Observe that the correspondence $\varphi \rightarrow \Lambda$ is bijective. We will use as well the correspondence in the other sense: every time we will have a matrix $\Lambda \in M_n(\mathbb{C}) \otimes M_n(\mathbb{C})$, we could speak about the associated linear map $\varphi : M_n(\mathbb{C}) \rightarrow M_n(\mathbb{C})$, via the above formula. This correspondence, when restricted to subclasses of (completely) positive maps, is known in quantum information theory as the Choi-Jamiolkowski isomorphism. See [7].

In order to get now more insight into the multiplicativity condition, we use the tensor planar algebra of Jones [14], or, equivalently, the diagrammatic formalism in [10]. We represent the matrices $\Lambda \in M_n(\mathbb{C}) \otimes M_n(\mathbb{C})$ as vertical boxes with 2 left legs and 2 right legs, so that the correspondence $\Lambda \rightarrow \varphi$ is the one described by Figure 1(a), where we write $\Lambda^\Gamma = (t \otimes id)\Lambda$ for the partially transposed map.

It will be often convenient to write Λ in usual matrix notation:

$$\Lambda = \sum_{abcd} \Lambda_{ab,cd} e_{ac} \otimes e_{bd}$$

With this convention, the associated linear map φ is given by:

$$\varphi(A)_{bd} = \sum_{ac} \Lambda_{ab,cd} A_{ac}$$

Observe also that, in terms of the above square matrix Λ , we have (see also Figure 1(b) for the diagram):

$$\tilde{W} = (id \otimes Tr \otimes id)[(1 \otimes (t \otimes id)\Lambda)(W \otimes 1)]$$

Finally, observe that, in matrix notation, the entries of \tilde{W} are given by:

$$\tilde{W}_{ia,jb} = \sum_{ef} \Lambda_{ea,fb} W_{ie,jf}$$

Given a complex linear functional $f : A \rightarrow \mathbb{C}$ and a permutation $\pi \in S_p$ we set $f_\pi(a) = \sum_{b \in \pi} f(a^{\#b})$ for any $a \in A$, where the sum is over all the cycles of π . We will use this notation throughout the remainder of the paper, often with f being the usual trace of matrices, $Tr : M_N(\mathbb{C}) \rightarrow \mathbb{C}$, or the normalized trace of matrices, $tr : M_N(\mathbb{C}) \rightarrow \mathbb{C}$. In the same vein, for a pair of permutations $(\pi, \sigma) \in S_p^2$, we write $f_{(\pi, \sigma)} = f_\pi \otimes f_\sigma$ for the operator acting on $A \otimes A$ as f_π on the first leg of the tensor and as f_σ on its second leg.

Theorem 2.4. *We have the asymptotic moment formula:*

$$\lim_{d \rightarrow \infty} (\mathbb{E} \circ tr)((m\tilde{W})^p) = \sum_{\pi \in NC(p)} (mn)^{|\pi|} tr_{(\pi, \gamma)}(\Lambda)$$

Proof. According to the above formula for the entries of \tilde{W} , we have:

$$\begin{aligned} tr(\tilde{W}^p) &= (dn)^{-1} \sum_{i_r a_r} \prod_s \tilde{W}_{i_s a_s, i_{s+1} a_{s+1}} \\ &= (dn)^{-1} \sum_{i_r a_r e_r f_r} \prod_s \Lambda_{e_s a_s, f_s a_{s+1}} W_{i_s e_s, i_{s+1} f_s} \\ &= (dn)^{-1} (dm)^{-p} \sum_{i_r a_r e_r f_r j_r b_r} \prod_s \Lambda_{e_s a_s, f_s a_{s+1}} G_{i_s e_s, j_s b_s} \bar{G}_{i_{s+1} f_s, j_s b_s} \end{aligned}$$

The average of the general term can be computed by the Wick rule:

$$\mathbb{E} \left(\prod_s G_{i_s e_s, j_s b_s} \bar{G}_{i_{s+1} f_s, j_s b_s} \right) = \#\{\pi \in S_p \mid i_{\pi(s)} = i_{s+1}, e_{\pi(s)} = f_s, j_{\pi(s)} = j_s, b_{\pi(s)} = b_s\}$$

Let us look now at the above sum. The i, j, b indices range over sets having respectively d, d, m elements, and they have to be constant under the action of $\pi\gamma^{-1}, \pi, \pi$. Thus when summing over these i, j, b indices we simply obtain a $d^{|\pi\gamma^{-1}|} d^{|\pi|} m^{|\pi|}$ factor, so we get:

$$\begin{aligned} (\mathbb{E} \circ tr)(\tilde{W}^p) &= (dn)^{-1} (dm)^{-p} \sum_{\pi \in S_p} d^{|\pi\gamma^{-1}|} (dm)^{|\pi|} \sum_{a_r e_r} \prod_s \Lambda_{e_s a_s, e_{\pi(s)} a_{s+1}} \\ &= n^{-1} m^{-p} \sum_{\pi \in S_p} d^{|\pi| + |\pi\gamma^{-1}| - p - 1} m^{|\pi|} Tr_{(\pi, \gamma)}(\Lambda) \\ &= m^{-p} \sum_{\pi \in S_p} d^{|\pi| + |\pi\gamma^{-1}| - p - 1} (mn)^{|\pi|} tr_{(\pi, \gamma)}(\Lambda) \end{aligned}$$

By Lemma 2.1, with $d \rightarrow \infty$ the sum restricts over $\pi \in NC(p)$, and we are done. \square

One can also prove the result using the graphical Wick technique developed in [11]. There is an obvious relation between the above result and the combinatorics of the compound free Poisson laws. More precisely, we have the following similar result:

Theorem 2.5. *If $\Lambda = \Lambda^*$ then the moments of $\pi_{mn\rho}$, with $\rho = \text{law}(\Lambda)$, are:*

$$M_p = \sum_{\pi \in NC(p)} (mn)^{|\pi|} \text{tr}_{(\pi, \pi)}(\Lambda)$$

Proof. We know from Theorem 1.6 that the free cumulants of $\pi_{mn\rho}$ are the moments of $mn\rho$, given by $\kappa_p = mn \cdot \text{tr}(\Lambda^p) = mn \cdot \text{tr}_{(\gamma, \gamma)}(\Lambda)$. Together with Speicher's moment-cumulant formula, explained in section 1 above, this gives the result. \square

In what follows we will try to exploit the obvious similarity between Theorem 2.4 and Theorem 2.5. We will split our study into 2 parts: the unital case will be investigated in section 3, and the general, non-unital case will be investigated in section 4.

3. THE UNITAL CASE

A linear map $\varphi : M_n(\mathbb{C}) \rightarrow M_n(\mathbb{C})$ is called self-adjoint if $A = A^*$ implies $\varphi(A) = \varphi(A)^*$. This is the same as asking for the corresponding matrix Λ to be self-adjoint.

Theorem 3.1. *Assume that φ is self-adjoint. If $\text{tr}_{(\pi, \gamma)}(\Lambda) = \text{tr}_{(\pi, \pi)}(\Lambda)$ for any $p \in \mathbb{N}$ and any $\pi \in NC(p)$, then $m\tilde{W} \sim \pi_{mn\rho}$, with $\rho = \text{law}(\Lambda)$.*

Proof. We know from Theorem 2.4 and Theorem 2.5 that the formula $m\tilde{W} \sim \pi_{mn\rho}$ is equivalent to the following formula, which should be valid for any $p \in \mathbb{N}$:

$$\sum_{\pi \in NC(p)} (mn)^{|\pi|} \text{tr}_{(\pi, \gamma)}(\Lambda) = \sum_{\pi \in NC(p)} (mn)^{|\pi|} \text{tr}_{(\pi, \pi)}(\Lambda)$$

Now since in the case $\text{tr}_{(\pi, \gamma)}(\Lambda) = \text{tr}_{(\pi, \pi)}(\Lambda)$ this formula holds, we are done. \square

The point now is that, in all the examples that we have, the above result applies only when φ is unital modulo scalars. The non-unital case, which requires a more subtle combination of Theorem 2.4 and Theorem 2.5, will be discussed in the next section.

For a matrix $A \in M_n(\mathbb{C})$ we denote by $A^\delta \in M_n(\mathbb{C})$ its diagonal.

Theorem 3.2. *The formula $\text{tr}_{(\pi, \gamma)}(\Lambda) = \text{tr}_{(\pi, \pi)}(\Lambda)$ holds for any map which is unital modulo scalars, in the sense that $\varphi(1) = c1$ with $c \in \mathbb{C} - \{0\}$, of the following form:*

- (1) $\varphi(A) = \text{Tr}(BA)C$.
- (2) $\varphi(A) = BAC$.
- (3) $\varphi(A) = BA^t C$.
- (4) $\varphi(A) = B(EAF)^\delta C$.

In addition, the set of above maps is stable by composition and inversion, and the formula $\text{tr}_{(\pi, \gamma)}(\Lambda) = \text{tr}_{(\pi, \pi)}(\Lambda)$ is stable by taking tensor products, and multiplying by scalars.

Proof. If we write $\Lambda = \sum_{abcd} \Lambda_{ab,cd} e_{ac} \otimes e_{bd}$, then $\varphi(A)_{bd} = \sum_{ac} \Lambda_{ab,cd} A_{ac}$. This shows that in the cases (1-3) we have $\Lambda_{ab,cd} = B_{ca} C_{bd}, B_{ba} C_{cd}, B_{bc} C_{ad}$ respectively.

Let us compute the numbers $Tr_{(\pi,\sigma)}(\Lambda) = \sum_{a_r e_r} \prod_s \Lambda_{e_s a_s, e_{\pi(s)} a_{\sigma(s)}}$:

$$\begin{aligned} Tr_{(\pi,\sigma)}(\Lambda^1) &= \sum_{a_r e_r} \prod_s B_{e_{\pi(s)} e_s} C_{a_s a_{\sigma(s)}} = Tr_{\pi}(B) Tr_{\sigma}(C) \\ Tr_{(\pi,\sigma)}(\Lambda^2) &= \sum_{a_r e_r} \prod_s B_{a_s e_s} C_{e_{\pi(s)} a_{\sigma(s)}} = Tr_{\pi\sigma^{-1}}(BC) \\ Tr_{(\pi,\sigma)}(\Lambda^3) &= \sum_{a_r e_r} \prod_s B_{a_s e_{\pi(s)}} C_{e_s a_{\sigma(s)}} = Tr_{\sigma\pi}(BC) \end{aligned}$$

In the case (4) now, we have $\Lambda_{ab,cd} = \sum_x B_{bx} E_{xa} F_{cx} C_{xd}$, and we get:

$$Tr_{(\pi,\sigma)}(\Lambda^4) = \sum_{a_r e_r x_r} \prod_s B_{a_s x_s} E_{x_s e_s} F_{e_{\pi(s)} x_s} C_{x_s a_{\sigma(s)}} = \sum_{x_r} \prod_s (CB)_{x_s x_{\sigma(s)}} (EF)_{x_{\pi(s)} x_s}$$

Assume now that the maps φ are unital modulo scalars, with $C = c1$ in (1), with $BC = c1$ in (2,3), and with $(CB)(EF)^\delta = c1$ in (4). We get that:

$$\begin{aligned} tr_{(\pi,\sigma)}(\Lambda^1) &= tr_{\pi}(B) tr_{\sigma}(C) = c^p tr_{\pi}(B) \\ tr_{(\pi,\sigma)}(\Lambda^2) &= n^{|\pi\sigma^{-1}| - |\pi| - |\sigma|} tr_{\pi\sigma^{-1}}(BC) = n^{|\pi\sigma^{-1}| - |\pi| - |\sigma|} c^p \\ tr_{(\pi,\sigma)}(\Lambda^3) &= n^{|\sigma\pi| - |\pi| - |\sigma|} tr_{\sigma\pi}(BC) = n^{|\sigma\pi| - |\pi| - |\sigma|} c^p \\ tr_{(\pi,\sigma)}(\Lambda^4) &= n^{-|\pi| - |\sigma|} \sum_{x \leq \ker(\pi \wedge \sigma)} (CB)_{xx} (EF)_{xx} = n^{|\pi \wedge \sigma| - |\pi| - |\sigma|} c^p \end{aligned}$$

We claim that we have $tr_{(\pi,\gamma)}(\Lambda) = tr_{(\pi,\pi)}(\Lambda)$ in all cases. Indeed, in case (1) this is clear, and in (2-4) this follows from the following equalities for the exponents of n :

$$\begin{aligned} (p+1 - |\pi|) - |\pi| - 1 &= p - |\pi| - |\pi| \\ (||\pi|| + 1) - |\pi| - 1 &= (|\pi| + ||\pi||) - |\pi| - |\pi| \\ 1 - |\pi| - 1 &= |\pi| - |\pi| - |\pi| \end{aligned}$$

Regarding now the stability properties, the inverses of the maps (1-4) are also of type (1-4). Also, the maps (1-4) are stable by composition, the formula for $i \circ j$ being:

$$\begin{array}{c|cccc} i \backslash j & 1 & 2 & 3 & 4 \\ \hline 1 & 1 & 1 & 1 & 1 \\ 2 & 1 & 2 & 3 & 4 \\ 3 & 1 & 3 & 2 & 4 \\ 4 & 1 & 4 & 4 & 4 \end{array}$$

For the tensor product assertion now, assume that $\varphi = \varphi^1 \otimes \varphi^2$. We have then $\Lambda = \Lambda^1 \otimes \Lambda^2$, so in matrix notation $\Lambda_{a\alpha b\beta, c\gamma d\delta} = \Lambda_{ab, cd}^1 \Lambda_{\alpha\beta, \gamma\delta}^2$, and we get:

$$\begin{aligned} Tr_{(\pi, \sigma)}(\Lambda) &= \sum_{a_r \alpha_r e_r \varepsilon_r} \prod_s \Lambda_{e_s \varepsilon_s a_s \alpha_s, e_{\pi(s)} \varepsilon_{\pi(s)} a_{\sigma(s)} \alpha_{\sigma(s)}} \\ &= \sum_{a_r \alpha_r e_r \varepsilon_r} \prod_s \Lambda_{e_s a_s, e_{\pi(s)} a_{\sigma(s)}}^1 \Lambda_{\varepsilon_s \alpha_s, \varepsilon_{\pi(s)} \alpha_{\sigma(s)}}^2 \\ &= Tr_{(\pi, \sigma)}(\Lambda^1) Tr_{(\pi, \sigma)}(\Lambda^2) \end{aligned}$$

It follows that $tr_{(\pi, \sigma)}(\Lambda) = tr_{(\pi, \sigma)}(\Lambda^1) tr_{(\pi, \sigma)}(\Lambda^2)$, and we are done. Finally, the assertion regarding the multiplication by scalars is clear. \square

As a first consequence, we obtain some previously known results, from [11], [16], [5]:

Proposition 3.3. *We have the following results:*

- (1) $t(id \otimes tr(\cdot)1)W \sim \pi_t$, where $t = mn$.
- (2) $tW \sim \pi_t$, where $t = m/n$.
- (3) $m(id \otimes t)W \sim law(\alpha - \beta)$, where α, β are free Poisson $(m(n \pm 1)/2)$, free.
- (4) $m(id \otimes (\cdot)^\delta)W \sim \pi_m$.

Proof. Our claim is that (1-4) above correspond via Theorem 3.1 to the assertions (1-4) in Theorem 3.2, at $B = C = 1$. Indeed, let us see what happens in this case:

(1) Here we have $\varphi(A) = Tr(A)1$, hence $\tilde{W} = (id \otimes Tr(\cdot)1)W$. Also, we have $\Lambda_{ab, cd} = \delta_{ca}\delta_{bd}$, hence $\Lambda = \sum_{ab} e_{aa} \otimes e_{bb}$ is the identity matrix: $\Lambda = 1$. Thus $\rho = \delta_1$, so $\pi_{mn\rho} = \pi_{mn}$, so Theorem 3.2 says at $B = C = 1$ that we have $m\tilde{W} \sim \pi_{mn}$, as claimed.

(2) Here we have $\varphi(A) = A$, so $\tilde{W} = W$. Also, we have $\Lambda_{ab, cd} = \delta_{ab}\delta_{cd}$, hence $\Lambda = \sum_{ac} e_{ac} \otimes e_{ac}$, so we have $\Lambda = nP$, where P is the rank one projection on the vector $\sum_a e_a \otimes e_a \in \mathbb{C}^n \otimes \mathbb{C}^n$. Thus $\rho = \frac{n^2-1}{n^2}\delta_0 + \frac{1}{n^2}\delta_n$, so $mn\rho = \frac{m(n^2-1)}{n}\delta_0 + \frac{m}{n}\delta_n$, so $\pi_{mn\rho} = law(n\alpha)$, where α is free Poisson (m/n) . Thus Theorem 3.2 says at $B = C = 1$ that we have $mW \sim law(n\alpha)$, and by dividing by n we get $(m/n)W \sim law(\alpha)$, as claimed.

(3) Here we have $\varphi(A) = A^t$, so $\tilde{W} = (id \otimes t)W$. Also, we have $\Lambda_{ab, cd} = \delta_{bc}\delta_{ad}$, so $\Lambda = \sum_{ac} e_{ac} \otimes e_{ca}$ is the flip: $\Lambda(e_c \otimes e_a) = e_a \otimes e_c$. Thus $\rho = \frac{n-1}{2n}\delta_{-1} + \frac{n+1}{2n}\delta_1$, so $mn\rho = \frac{m(n-1)}{2}\delta_{-1} + \frac{m(n+1)}{2}\delta_1$, so $\pi_{mn\rho} = law(\alpha - \beta)$, where α, β are as in the statement. Thus Theorem 3.2 says at $B = C = 1$ that we have $m\tilde{W} \sim law(\alpha - \beta)$, as claimed.

(4) Here we have $\varphi(A) = A^\delta$, so $\tilde{W} = (id \otimes (\cdot)^\delta)W$. Also, we have $\Lambda_{ab, cd} = \delta_{a,b,c,d}$, hence $\Lambda = \sum_a e_{aa} \otimes e_{aa}$ is the orthogonal projection on $span(e_a \otimes e_a) \subset \mathbb{C}^n \otimes \mathbb{C}^n$. Thus we have $\rho = \frac{n-1}{n}\delta_0 + \frac{1}{n}\delta_1$, so $mn\rho = m(n-1)\delta_0 + m\delta_1$, so $\pi_{mn\rho} = \pi_m$. Thus Theorem 3.2 says at $B = C = 1$ that we have $m\tilde{W} \sim \pi_m$, as claimed. \square

We have as well the following generalization, obtained by taking a tensor product:

Proposition 3.4. *For a linear map of type $\varphi = id \otimes (tr(\cdot)1) \otimes id \otimes t \otimes (\cdot)^\delta$ we have $t\tilde{W} \sim law(\alpha - \beta)$, where α, β are free Poisson $(t(n_3 \pm 1)/2)$, free, with $t = mn_1/n_2$.*

Proof. We have $\Lambda = (n_2/n_1)(1 \otimes P \otimes \Sigma \otimes Q)$, where P, Σ, Q are the matrices appearing in the above proof, namely: P is a rank 1 projection in n_2^2 dimensions, Σ is the flip in n_3^2 dimensions, and Q is a rank n_4 projection in n_4^2 dimensions. Since $P \otimes Q$ is a rank n_4 projection in $(n_2 n_4)^2$ dimensions, the matrix $P \otimes \Sigma \otimes Q$ follows the following law:

$$\eta = \frac{n_2^2 n_4 - 1}{n_2^2 n_4} \delta_0 + \frac{n_3 - 1}{2n_2^2 n_3 n_4} \delta_{-1} + \frac{n_3 + 1}{2n_2^2 n_3 n_4} \delta_1$$

Now since tensoring with *id* doesn't change the law, it follows that ρ is the measure obtained from η by replacing the ± 1 atoms by $\pm n_2/n_1$ atoms, so we have:

$$mn\rho = \frac{mn_1 n_3 (n_2^2 n_4 - 1)}{n_2} \delta_0 + \frac{mn_1 (n_3 - 1)}{2n_2} \delta_{-n_2/n_1} + \frac{mn_1 (n_3 + 1)}{2n_2} \delta_{n_2/n_1}$$

By using Theorem 3.1 and Theorem 3.2 it follows that $m\tilde{W} \sim \text{law}((n_2/n_1)(\alpha - \beta))$, where α, β are as in the statement, and by multiplying by n_1/n_2 we obtain the result. \square

4. THE MAIN RESULT

In this section we investigate the general, non-unital case. Let us first work out a generalization of Theorem 3.1, which will prove to be well-adapted to this case.

Theorem 4.1. *Assume that φ is self-adjoint. If for any $p \in \mathbb{N}$ and $\pi \in NC(p)$ we have*

$$\text{tr}_{(1,1)}(\Lambda) \text{tr}_{(\pi,\gamma)}(\Lambda) = \text{tr}_{(1,\pi\gamma^{-1})}(\Lambda) \text{tr}_{(\pi,\pi)}(\Lambda)$$

then $\delta m\tilde{W} \sim \pi_{mn\rho} \boxtimes \nu$, with $\rho = \text{law}(\Lambda)$, $\nu = \text{law}(D)$, $\delta = \text{tr}(D)$, where $D = \varphi(1)$.

Proof. The entries of $D = \varphi(1)$ are given by $D_{bd} = \sum_a \Lambda_{ab,ad}$, so we get:

$$\text{tr}_\sigma(D) = \sum_{e_r} \prod_s D_{e_r e_{\sigma(r)}} = \sum_{ae_r} \Lambda_{ae_r, ae_{\sigma(r)}} = \text{tr}_{(1,\sigma)}(\Lambda)$$

In particular at $\sigma = 1$ we obtain $\delta^p = \text{tr}_{(1,1)}(\Lambda)$, so Theorem 2.4 gives:

$$\lim_{d \rightarrow \infty} (\mathbb{E} \circ \text{tr})((\delta m\tilde{W})^p) = \sum_{\pi \in NC(p)} (mn)^{|\pi|} \text{tr}_{(1,1)}(\Lambda) \text{tr}_{(\pi,\gamma)}(\Lambda)$$

We use the following formula from [17] for of a multiplicative free convolution:

$$\mathbb{E}((AB)^p) = \sum_{\pi \in NC(p)} \prod_{b \in \pi} \mathbb{E}_{\pi\gamma^{-1}}(B) \kappa_\pi(A)$$

We know from Theorem 1.6 that the free cumulants of $\pi_{mn\rho}$ are the moments of $mn\rho$, given by $\kappa_p = mn \cdot \text{tr}(\Lambda^p) = mn \cdot \text{tr}_{(\gamma,\gamma)}(\Lambda)$. Thus the abstract free cumulants of $\pi_{mn\rho}$ are the numbers $\kappa_\pi = (mn)^{|\pi|} \text{tr}_{(\pi,\pi)}(\Lambda)$. Together with the formula $\text{tr}_\sigma(D) = \text{tr}_{(1,\sigma)}(\Lambda)$ above, the above general formula from [17] shows that the moments of $\pi_{mn\rho} \boxtimes \nu$ are:

$$M_p = \sum_{\pi \in NC(p)} (mn)^{|\pi|} \text{tr}_{(1,\pi\gamma^{-1})}(\Lambda) \text{tr}_{(\pi,\pi)}(\Lambda)$$

We conclude that the formula $\delta m \tilde{W} \sim \pi_{mn\rho} \boxtimes \nu$ is equivalent to:

$$\sum_{\pi \in NC(p)} (mn)^{|\pi|} tr_{(1,1)}(\Lambda) tr_{(\pi,\gamma)}(\Lambda) = \sum_{\pi \in NC(p)} (mn)^{|\pi|} tr_{(1,\pi\gamma^{-1})}(\Lambda) tr_{(\pi,\pi)}(\Lambda)$$

With this equivalence in hand, the assertion in the statement is now clear. \square

The above result suggests the following technical definition:

Definition 4.2. *A map φ and the corresponding matrix Λ are called “multiplicative” if*

$$tr_{(1,1)}(\Lambda) tr_{(\pi,\gamma)}(\Lambda) = tr_{(1,\pi\gamma^{-1})}(\Lambda) tr_{(\pi,\pi)}(\Lambda)$$

for any $p \in \mathbb{N}$ and $\pi \in NC(p)$.

Observe that in this definition one can replace the normalized traces tr by the unnormalized traces Tr : this follows indeed from $Tr_{(\pi,\sigma)}(\Lambda) = n^{|\pi|+|\sigma|} tr_{(\pi,\sigma)}(\Lambda)$.

As already mentioned, this definition is a technical one, coming straight from Theorem 4.1, which in turn comes from abstract algebraic manipulations. There is no simpler formulation of it, but in what follows we will try to have some understanding of it.

Let us extend now Theorem 3.2 above. We have the following result here:

Theorem 4.3. *The following types of maps and matrices are multiplicative:*

- (1) $\varphi(A) = Tr(BA)C$, or $\Lambda = B \otimes C$, in the case $C = c1$.
- (2) $\varphi(A) = BAC$, or $\Lambda = |B\rangle\langle C|$, for any B, C .
- (3) $\varphi(A) = BA^t C$, or $\Lambda = \text{SWAP}_{BC}$, in the case $BC = c1$.
- (4) $\varphi(A) = xA^\delta$, or $\Lambda = \text{Center}_x$, in the case $x = c1$.

In addition, the set of multiplicative maps and matrices is stable by tensor products.

Proof. (1,3,4) follow from Theorem 3.2, and the last assertion follows from the proof of Theorem 3.2. For proving (2) we use a formula found in the proof of Theorem 3.2:

$$Tr_{(\pi,\sigma)}(\Lambda) = Tr_{\pi\sigma^{-1}}(BC)$$

In terms of normalized traces, and with $D = BC$, we get:

$$tr_{(\pi,\sigma)}(\Lambda) = n^{|\pi\sigma^{-1}|-|\pi|-|\sigma|} tr_{\pi\sigma^{-1}}(D)$$

In particular we have the following formulae:

$$\begin{aligned} tr_{1,1}(\Lambda) &= n^{p-p-p} tr_1(D) = n^{-p} tr_1(D) \\ tr_{\pi,\gamma}(\Lambda) &= n^{(p+1-|\pi|)-|\pi|-1} tr_{\pi\gamma^{-1}}(D) = n^{p-2|\pi|} tr_{\pi\gamma^{-1}}(D) \\ tr_{1,\pi\gamma^{-1}}(\Lambda) &= n^{(p+1-|\pi|)-p-(p+1-|\pi|)} tr_{\pi\gamma^{-1}}(D) = n^{-p} tr_{\pi\gamma^{-1}}(D) \\ tr_{\pi,\pi}(\Lambda) &= n^{p-|\pi|-|\pi|} tr_1(D) = n^{p-2|\pi|} tr_1(D) \end{aligned}$$

By multiplying we obtain the formula in the statement. \square

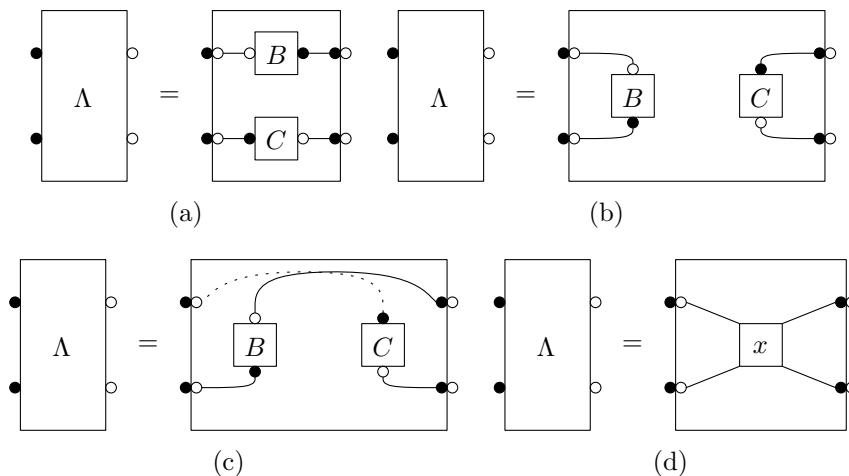

FIGURE 2. Special types of matrices Λ whose mixed moments factorize properly.

Using the graphical notation from [10], the diagrams for the maps of type (1-4) in Theorem 4.3 are some very simple ones, namely those in Figure 2.

So, let us try to combine the diagrams in Figure 2 in a “planar” way. We call “generalized Center_c diagram” the diagram Λ having k left legs and l right legs, given by:

$$\Lambda_{i_1 \dots i_k, j_1 \dots j_l} = c \cdot \delta_{i_1, \dots, i_k, j_1, \dots, j_l}$$

The following planar-categorical definition is inspired from [14], [10]:

Definition 4.4. The “strings and beads” operad \mathcal{P} is defined as follows:

- (1) The elements are the matrices $\Lambda \in (M_{n_1}(\mathbb{C}) \otimes \dots \otimes M_{n_k}(\mathbb{C}))^{\otimes 2}$, represented by vertical boxes with $2k$ left legs and $2k$ right legs.
- (2) The legs are colored by the values of the corresponding n_i numbers, and the tensor product and composition operations have to match colors.
- (3) Inside the box we have “strings” joining the $2k + 2k$ legs, i.e. we have a partition of $2k + 2k$ elements into even blocks $\pi \in P_{\text{even}}(2k, 2k)$, with colors matching.
- (4) Each string can be decorated with “beads”, i.e. with usual matrices $A \in M_n(\mathbb{C})$, where n is the color of the string.
- (5) The “multi-leg” strings, representing blocks of $\pi \in P_{\text{even}}(2k, 2k)$ having size ≥ 4 , have at the multi-crossing a “small bead”, of generalized Center_c type.

In other words, the matrices $\Lambda \in (M_{n_1}(\mathbb{C}) \otimes \dots \otimes M_{n_k}(\mathbb{C}))^{\otimes 2}$ will be represented as diagrams having the left and right sequences of $2k$ points marked $n_1, \dots, n_k, n_k, \dots, n_1$, from top to bottom. In order to view such a matrix as $\Lambda \in M_{n_1 \dots n_k}(\mathbb{C}) \otimes M_{n_k \dots n_1}(\mathbb{C})$, we will simply “compact the blocks”, i.e. we will view Λ as a diagram between 2 left points and 2 right points, with both 2-series labeled $n_1 \dots n_k, n_k \dots n_1$, from top to bottom.

We know from Theorem 4.3 that the 4 types of diagrams appearing there, as well as their tensor products, are multiplicative in the sense of Definition 4.2. The challenging question is to determine all the elements of \mathcal{P} which are multiplicative.

Let us call “through” strings of $\Lambda \in \mathcal{P}$ the strings of the corresponding partition, joining left and right points. With this convention, we have the following result:

Proposition 4.5. *Assume that $\Lambda \in \mathcal{P}$ is self-adjoint, and that its through strings are not decorated with beads. Then Λ is multiplicative.*

Proof. The element Λ consists by definition of a partition $x \in P_{\text{even}}(2k, 2k)$, decorated with beads. Since Λ is self-adjoint, x is “symmetric”, in the sense that it is invariant under the reflection with respect to the vertical middle axis. We decompose $x = \sqcup_{i \in I} b_i$, where b_i are blocks or pairs of blocks of x , chosen symmetric, and with $|I|$ maximal.

For any such “symmetric block” b_i we denote by $\Lambda_i \in \mathcal{P}$ the element obtained from Λ by keeping b_i with its beads, and by completing with (undecorated) horizontal strings.

It follows from definitions that we have:

$$Tr_{(\pi, \sigma)}(\Lambda) = \prod_{i \in I} Tr_{(\pi, \sigma)}(\Lambda_i)$$

This formula shows that the multiplicativity condition splits over the symmetric blocks. Now for the symmetric blocks consisting of pairings, the result follows from Theorem 4.3 above. So, it remains to prove that the symmetrization $\tilde{\Lambda}$ of any generalized Center $_c$ type partition Λ is multiplicative. By adding an extra string if needed we can assume that Λ has an even number of legs at left and at right, and we have two cases here:

(1) $\tilde{\Lambda} = \Lambda$. Here the formula of Λ is as follows, with $m \in \{2k - 1, 2k\}$:

$$\Lambda_{i_1 \dots i_{2k}, j_1 \dots j_{2k}} = c \cdot \delta_{i_1, \dots, i_m, j_1, \dots, j_m} \delta_{i_{m+1} \dots i_{2k}, j_{m+1} \dots j_{2k}}$$

With these notations, the mixed trace is given by:

$$\begin{aligned} Tr_{(\pi, \sigma)}(\Lambda) &= \sum_{i_1^r \dots i_k^r} \prod_l \Lambda_{i_1^l \dots i_{2k}^l, i_1^{\pi(l)} \dots i_k^{\pi(l)} i_{k+1}^{\sigma(l)} \dots i_{2k}^{\sigma(l)}} \\ &= \sum_{i_1^r \dots i_k^r} \prod_l c \cdot \delta_{i_1^l, \dots, i_m^l, i_1^{\pi(l)}, \dots, i_k^{\pi(l)}, i_{k+1}^{\sigma(l)}, \dots, i_m^{\sigma(l)}} \delta_{i_{m+1}^l \dots i_{2k}^l, i_{m+1}^{\sigma(l)} \dots i_{2k}^{\sigma(l)}} \\ &= c^p \cdot n^{|\pi \wedge \sigma|} \cdot n^{(2k-m)|\sigma|} \end{aligned}$$

Now since both $n^{|\pi \wedge \sigma|}$ and $n^{|\sigma|}$ are multiplicative, this gives the result.

(2) $\tilde{\Lambda} \neq \Lambda$. Here the formula of Λ is as follows, with $m \in \{2k - 1, 2k\}$:

$$\begin{aligned} \tilde{\Lambda}_{i_1 \dots i_{2k}, j_1 \dots j_{2k}} &= c^2 \cdot \delta_{i_1, \dots, i_s, i_{k+1}, \dots, i_{k+t}, j_{s+1}, \dots, j_k, j_{k+t+1}, \dots, j_m} \\ &\quad \delta_{i_{s+1}, \dots, i_k, i_{k+t+1}, \dots, i_m, j_1, \dots, j_s, j_{k+1}, \dots, j_{k+t}} \\ &\quad \delta_{i_{m+1} \dots i_{2k}, j_{m+1} \dots j_{2k}} \end{aligned}$$

With these notations, the mixed trace is given by:

$$\begin{aligned} \text{Tr}_{(\pi,\sigma)}(\Lambda) &= \sum_{i_1^r \dots i_k^r} \prod_l c \cdot \delta_{i_1^l, \dots, i_s^l, i_{k+1}^l, \dots, i_{k+t}^l, i_{s+1}^{\pi(l)}, \dots, i_k^{\pi(l)}, i_{k+t+1}^{\sigma(l)}, \dots, i_m^{\sigma(l)}} \\ &\quad \delta_{i_{s+1}^l, \dots, i_k^l, i_{k+t+1}^l, \dots, i_m^l, i_1^{\pi(l)}, \dots, i_s^{\pi(l)}, i_{k+1}^{\sigma(l)}, \dots, i_{k+t}^{\sigma(l)}} \\ &\quad \delta_{i_{m+1}^l \dots i_{2k}^l, i_{m+1}^{\sigma(l)} \dots i_{2k}^{\sigma(l)}} \end{aligned}$$

By looking at the indices we obtain $\text{Tr}_{(\pi,\sigma)}(\Lambda) = c^2 \cdot n^{2|\pi \wedge \sigma|} \cdot n^{(2k-m)|\sigma|}$, and since both the quantities $n^{|\pi \wedge \sigma|}$ and $n^{|\sigma|}$ are multiplicative, we are done. \square

We can state and prove now our main result:

Theorem 4.6. *Let W be a complex Wishart matrix of parameters (dn, dm) , and let $\varphi : M_n(\mathbb{C}) \rightarrow M_n(\mathbb{C})$ be a linear map coming from “strings and beads” diagram $\Lambda \in \mathcal{P}$, which is symmetric and has undecorated through strings. Then the $d \rightarrow \infty$ asymptotic eigenvalue distribution of the block-modified Wishart matrix $\tilde{W} = (id \otimes \varphi)W$ is given by $\delta m \tilde{W} \sim \pi_{mn\rho} \boxtimes \nu$, with $\rho = \text{law}(\Lambda)$, $\nu = \text{law}(D)$, $\delta = \text{tr}(D)$, where $D = \varphi(1)$.*

Proof. We know from Proposition 4.5 that Λ is multiplicative in the sense of Definition 4.2. Thus Theorem 4.1 applies, and gives the result. \square

Observe that Theorem 4.6 doesn’t fully cover Theorem 4.3. The problem is that, when trying to fully combine the diagrams in Theorem 4.3, our formula $\delta m \tilde{W} \sim \pi_{mn\rho} \boxtimes \nu$ seems to need a kind of substantial upgrade, with more quantities involved on the right. This kind of upgrade is also suggested by the various questions raised in the introduction, but finding it is of course a quite difficult problem, that we would like to raise here.

REFERENCES

- [1] N. Alexeev, F. Götze and A. Tikhomirov, On the asymptotic distribution of singular values of power of random matrices, *Lithuanian Math. Journal* **50** (2010), 121–132.
- [2] G. Aubrun, Partial transposition of random states and non-centered semicircular distributions, *Random Matrices: Theory Appl.*, **1** (2012), 125–145.
- [3] T. Banica, S.T. Belinschi, M. Capitaine and B. Collins, Free Bessel laws, *Canad. J. Math.* **63** (2011), 3–37.
- [4] T. Banica, J. Bichon and B. Collins, The hyperoctahedral quantum group, *J. Ramanujan Math. Soc.* **22** (2007), 345–384.
- [5] T. Banica and I. Nechita, Asymptotic eigenvalue distributions of block-transposed Wishart matrices, *J. Theoret. Probab.*, to appear.
- [6] T. Banica and A. Skalski, Quantum isometry groups of duals of free powers of cyclic groups, *Int. Math. Res. Not.* **9** (2012), 2094–2122.
- [7] I. Bengtsson and K. Życzkowski, *Geometry of quantum states*, Cambridge Univ. Press (2006).
- [8] P. Biane, Some properties of crossings and partitions, *Discrete Math.* **175** (1997), 41–53.
- [9] W. Bryc, Compound real Wishart and q -Wishart matrices, *Int. Math. Res. Not.* **79** (2008), 1–42.
- [10] B. Collins and I. Nechita, Random quantum channels I: graphical calculus and the Bell state phenomenon, *Comm. Math. Phys.* **297** (2010), 345–370.

- [11] B. Collins and I. Nechita, Gaussianization and eigenvalue statistics for random quantum channels (III), *Ann. Appl. Probab.* **21** (2011), 1136–1179.
- [12] P. Graczyk, G. Letac and H. Massam, The complex Wishart distribution and the symmetric group, *Ann. Statist.* **31** (2003), 287–309.
- [13] F. Hiai and D. Petz, The semicircle law, free random variables and entropy, AMS (2000).
- [14] V.F.R. Jones, Planar algebras I, [arxiv:math/9909027](https://arxiv.org/abs/math/9909027).
- [15] R. Lenczewski, Limit distributions of random matrices, [arxiv:1208.3586](https://arxiv.org/abs/1208.3586).
- [16] V.A. Marchenko and L.A. Pastur, Distribution of eigenvalues in certain sets of random matrices, *Mat. Sb.* **72** (1967), 507–536.
- [17] A. Nica and R. Speicher, Lectures on the combinatorics of free probability, Cambridge Univ. Press (2006).
- [18] S. O’Rourke and A. Soshnikov, Products of independent non-Hermitian random matrices, *Electron. J. Probab.* **16** (2011), 2219–2245.
- [19] R. Speicher, Multiplicative functions on the lattice of noncrossing partitions and free convolution, *Math. Ann.* **298** (1994), 611–628.
- [20] R. Speicher, Combinatorial theory of the free product with amalgamation and operator-valued free probability theory, *Mem. Amer. Math. Soc.* **132** (1998).
- [21] D.V. Voiculescu, Addition of certain noncommuting random variables, *J. Funct. Anal.* **66** (1986), 323–346.
- [22] D.V. Voiculescu, Limit laws for random matrices and free products, *Invent. Math.* **104** (1991), 201–220.
- [23] D.V. Voiculescu, A strengthened asymptotic freeness result for random matrices with applications to free entropy, *Int. Math. Res. Not.* **1** (1998), 41–63.
- [24] D.V. Voiculescu, K.J. Dykema and A. Nica, Free random variables, AMS (1992).

T.B.: DEPARTMENT OF MATHEMATICS, CERGY-PONTOISE UNIVERSITY, 95000 CERGY-PONTOISE, FRANCE. teodor.banica@u-cergy.fr

I.N.: CNRS, LABORATOIRE DE PHYSIQUE THÉORIQUE, IRSAMC, UNIVERSITÉ DE TOULOUSE, UPS, 31062 TOULOUSE, FRANCE. nechita@irsamc.ups-tlse.fr